

TEXTAR®

TMD
FRICION

*TMD Friction Services GmbH
Schlebuscher Str. 99
51381 Leverkusen
Deutschland
info@textar.com*

Textar is a registered trademark of TMD Friction.

www.textar.com

TEXTAR®

Fault assessment of disc brake pads and brake discs

Technical Information





Prerequisite for an optimally functioning brake

Prerequisite for an optimally functioning brake



Brake pads

- Selecting the brake pad according to Textar's recommendation
- Replacement procedure (axlewise) according to the sector-specific codes of practice in the fitting instructions.
- Running-in behaviour according to the recommendations of the vehicle manufacturer/fitting instructions.



Brake disc

- Clean functional surfaces
- Lateral run-out, parallelism, radial run-out and disc thickness variation according to Textar's recommendations
- Replacement procedure (axlewise) according to the recommendations of the vehicle manufacturer



Wheel brake

- Brake condition with clean, smoothly running guiding elements
- Operating elements (pistons, protective caps, springs, etc.) in undamaged operating condition



Wheels

- Balancing according to the guidelines of the vehicle manufacturer
- Fitting with the torques specified by the vehicle manufacturer and following the fitting instructions



Brake pads

Introduction

With few exceptions, disc brakes are used as wheel brakes on the front axle of passenger cars. Depending on the load, disc or drum brakes are used on the rear axle. The following remarks are limited to the disc brake.

High mechanical and thermal stress exerted on the brake system

The foot force exerted on the brake pedal, supported by the system, acts as tensioning force in the wheel brakes that presses the brake pads onto the brake discs. As a result of the friction force created by this, the greater portion of the kinetic energy of the vehicle is converted to heat within a short time. The mechanical and thermal stresses acting on the brake disc and brake pads are very high. In extreme cases, the braking power occurring during deceleration can be many times the maximum engine power.

Essential requirements with regard to the brake system

The essential requirements placed on a brake system can be summarised as follows:

- Minimum stopping distance under all operating conditions
- Good brake comfort (no judder, no squealing, good pedal feel)
- Adequate service life of the wearing parts.

As far as brake discs and brake pads as essential co-functioning elements for the braking procedure are concerned, this means:

- Frictional stability over a very wide temperature range
- Low dependence of the coefficient of friction on the contact pressure, speed and environmental influences
- Good mechanical strength and resistance to deformation
- Wear status within the specified limit values
- Component tolerances within the specified limit values
- Adequate wear behaviour of the brake pads and brake discs.

Brake discs and brake pads are co-functioning key safety elements. The requirements placed on them can only be met with components developed for/adapted to the vehicle concerned. Safety risks, as well as losses of comfort and a reduced service life can be avoided by correct maintenance.

High mechanical and thermal stress exerted on the brake system

Essential requirements with regard to the brake system



Brake pads

Brake noises in motor vehicles

Due to drivers' increased quality consciousness, brake noises are accepted less and less. What causes these, at times unpleasant noises and how can they be counteracted? When braking, vibrations always occur due to dry friction, which, depending on the frequency, are described with a wide variety of terms.

In the low frequency range, they are referred to as, e.g., rubbing, buzzing or juddering and in the medium and high frequency range, e.g., as squealing or wire brush.

In order to counteract these phenomena, TMD, Europe's leading brake pad manufacturer, has been carrying out intensive basic research for many years. At a very early phase of new vehicle development, the results contribute towards comfort optimisation.

Consequently, their intrinsic vibration behaviour and noise absorption properties are thoroughly tested when developing new brake pad materials. With the results achieved, the noise behaviour of new vehicles and their components are analysed and influenced on special noise test benches, in some cases, with complete prototype axle components and brakes. During this early development phase, changes can still be made to the wheel brake and pad contour.

At a later point in time, practice-oriented vehicles tests are then performed during which the intensity and frequency of any noises are determined. The test includes endurance runs in Spain, as well as assessment during a variety of street circuits and high-speed judder tests. In this context, it is of particular importance to determine which component vibrates at what frequency in order to be able to take targeted noise absorption measures. Fine adjustment can now be performed by small contour modifications such as grooves and/or chamfers. The compressibility of the brake pads can also be changed within the framework of the tolerance ranges.



Brake pads

Depending on the application, the wedge-shaped underlayer patented by TMD also contributes towards optimisation. In the ideal case, so-called secondary measures such as rubber varnish, adhesive foils, damping plates, counterweights, etc., can be dispensed with. Although these ancillary materials can contribute towards improvement, they also have an effect on the pedal feel, the wear volume and, naturally, the costs.

Consequently, in the case of a brake pad, a compromise must always be found between safety, comfort and economic efficiency.

In this context, the correct allocation of the different brake pad materials is just as important as the assessment of the overall condition of the complete wheel brake and the other axle and wheel suspension components.

One must also be aware that each change to the vehicle such as wide tyres, changes to the track, lowering, etc., also considerably affects the noise and comfort behaviour of motor vehicles.



Table of contents

Damage assessment of disc brake pads

Detachment of the friction material

- as a result of corrosion _____ 8–9
- as a result of thermal destruction _____ 10
- as a result of mechanical influences _____ 10
- as a result of faulty production _____ 11

Detachment of the friction material _____ 12–13 from the backing plate

Use-related damage

- Surface cracks _____ 14
- Edge break-offs _____ 15
- Delamination / edge deterioration _____ 16
- Faulty contact pattern _____ 17–18

Production fault _____ 19–20

Fitting fault _____ 21–24

Damage due to environmental influences _____ 25

Special fitting instructions _____ 26–27



Table of contents

Damage assessment of brake discs

Brake judder	28
Thermal judder	28–29
Cold judder	30–32
Judder caused by static spots	33
Squeaking noise during braking	33
Further possible defects	34
Brake discs exhibit cracking	34
Brake discs are scored	35
Brake disc service life is too short	35
Summary and illustrations	36
Thermal judder	37
Cold judder	37
Static spots	38
Cracked brake discs	38
Scored brake disc	39
Completely worn brake pads	39
Corroded brake discs	40
Inner and outer friction rings have different thicknesses	40
Thickness variation in friction ring	41
Heavy underlying corrosion at the contact surface	41
Blowhole damage	42
Cracks in the area of the brake disc chamber	42
Contact and Service	43
Notes	44–47



Brake pads

Detachment of the friction material due to corrosion

Cause:

- Edge detachment due to the use of new brake pads on extremely worn brake discs.
- Inadequate spring force of the hold-down spring (off-centre travel).
- Other mechanical overloading
- Constant high thermal stress on the disc brake pads.

- Friction material becomes porous (completely or in spots).
- Friction material has become disconnected due to corrosion.
- Backing plate has obvious traces of corrosion.
- Adhesive residue
- Underlayer and friction material visible on backing plate.

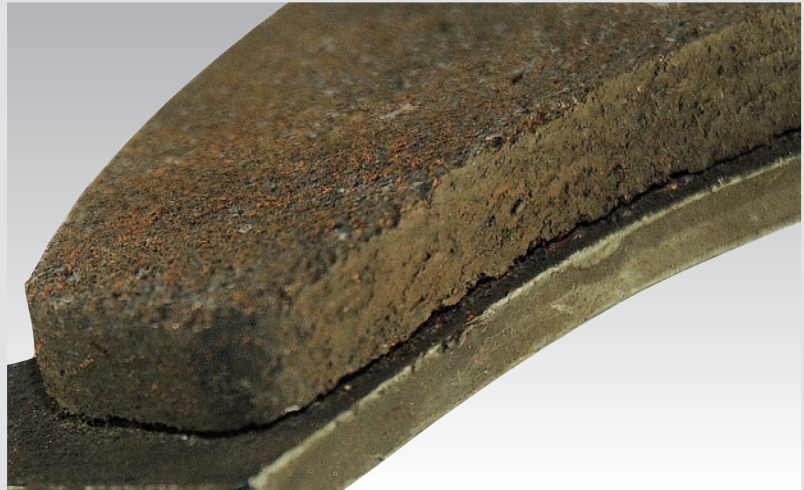

► Edge deterioration



► Heavy underlying corrosion



Brake pads

Detachment of the friction material due to corrosion



▶ No indication of excessive temperature load



▶ View: cross-section

Explanation:

The optically visible formulation components are present.

The graphite batch containing elastomers, as well as the friction carbon and aramide fibre, are still present up to directly under the friction layer.

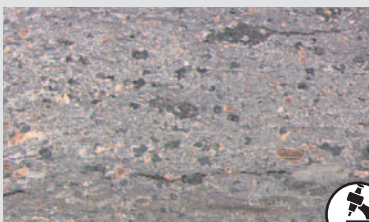

▶ Clear traces of thermal stress



▶ View: cross-section

Explanation:

The graphite batch containing elastomers no longer exists and the friction carbon is now only present up to directly above the underlayer.

The aramide fibre is still present under the friction layer (from approx. 4 mm onwards). Corrosion is visible below the underlayer.



Brake pads

Detachment of the friction material due to thermal destruction

Explanation:

Disc brake pads have exceeded the highest permissible temperature for longer than 15 – 20 minutes.

During this, constituents that contribute significantly towards stability are destroyed.



- Friction material decomposes, breaks off in some places and/or the underlayer and adhesive are damaged. Pad detaches completely; coating peels off. Partial colouring of the backing plate. Friction material has hardened, has a hard ring, reddish brown colouring of the friction material, white ash in some places.

due to mechanical influences

Explanation:

Disc brake pads have been dropped or fitted at a tilt or deformation due to extreme “wobbling” in the brake calliper.



The friction material detaches from the backing plate. Delamination occurs. Disc brake pads are new, separation above the adhesive/underlayer. Damage visible on the backing plate.



Damage as a result of bending stress visible on the backing plate.

Excessive “wobbling” in the backing plate.



Brake pads

Detachment of the friction material due to faulty production



- ▶ Friction material has already become detached when subject to low stress. There is insufficient adhesive.

Explanation:

- Backing plate smooth or underlayer and adhesive only partially visible.
- Adhesive not o.k. Underlayer improperly distributed.

Brake pads



Attention:

These faults often occur in combination.

Detachment of the friction material from the backing plate

Detachment due to	Cause
Corrosion	<ol style="list-style-type: none">1. Edge deterioration due to extremely worn brake disc; inadequate hold-down spring (off-centre travel)2. Constant high thermal stress on the disc brake pads
Faulty production	Adhesive not o.k. Underlayer improperly distributed.
Thermal destruction of adhesive, underlayer and friction material	Disc brake pads have exceeded the highest permissible temperature for longer than 15 – 20 minutes, during this, constituents that contribute significantly towards stability, are destroyed.
Mechanical destruction	Disc brake pads have, e.g., been dropped



Brake pads

Effect	Distinguishing characteristic
Friction material becomes porous (completely or in spots), friction material detachment as a result of corrosion	Backing plate has obvious traces of corrosion, adhesive residue, underlayer and friction material visible on backing plate
Friction material already becomes detached when subject to low stress	Backing plate smooth or underlayer and adhesive only partially visible
Friction material decomposes, breaks off in some places and/or the underlayer and adhesive are damaged, pad detaches completely	Coating peels off, backing plate is coloured blue in some places, friction material has hardened, has a hard ring, reddish brown colouring of the friction material, white ash in some places
Friction material detaches from the backing plate, delamination occurs	Disc brake pads are new, separation above the adhesive/underlayer. Damage visible on the backing plate.

Attention:

- Detachment can be due to various causes, only faulty production being within our sphere of influence and will, thus, be accepted as a complaint.
- Basically speaking, a wheel brake first becomes hot, and then the pad is destroyed.
- A sheared off brake pad is never the reason for a wheel brake to become hot.

Brake pads



Use-related damage Surface cracks



- ▶ Surface cracks can be ignored; they do not pose a safety risk. Even in the case of grooved brake pads, there is no disadvantage regarding pad stability.



Brake pads

Use-related damage Edge break-offs

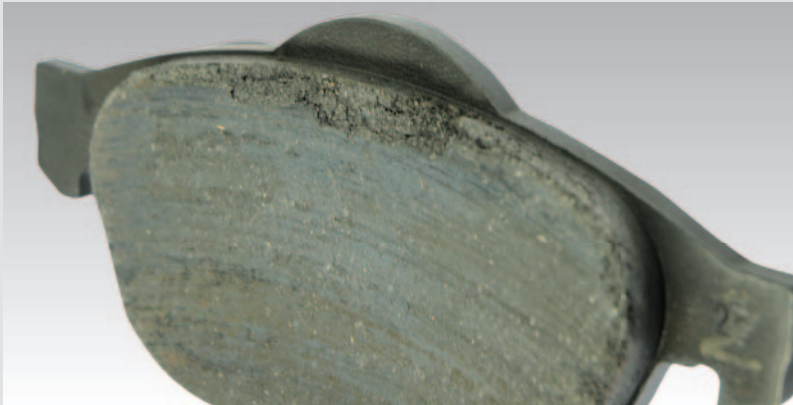

► Break-offs can be ignored; they do not pose a safety risk

Explanation:

- Type-related effects which, depending on the thermal or mechanical stress, can be pronounced to a different degree.
- Edge break-offs are permissible up to a maximum of 10% of the total friction surface.



► Break-offs are permissible in the area marked, however, up to a maximum of 10% of the total pad surface



Brake pads

Use-related damage Delamination / edge deterioration

Explanation:

- No break-offs or edge deterioration are permissible in this area.
- Cracks or deteriorations in the area where the friction material is connected are not permissible.

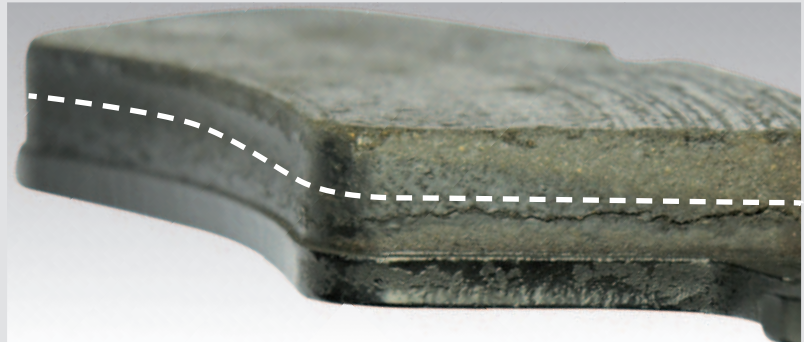

- ▶ Protected area where the pad is connected underneath the marking



- ▶ Pad with inadmissible deterioration

Brake pads



Use-related damage Faulty contact pattern



► Pad with inadequate contact pattern

Cause:

- Worn or incorrect brake disc
- Brake defect / contamination
- Insufficient brake loading
- See also Fitting fault/
Production fault

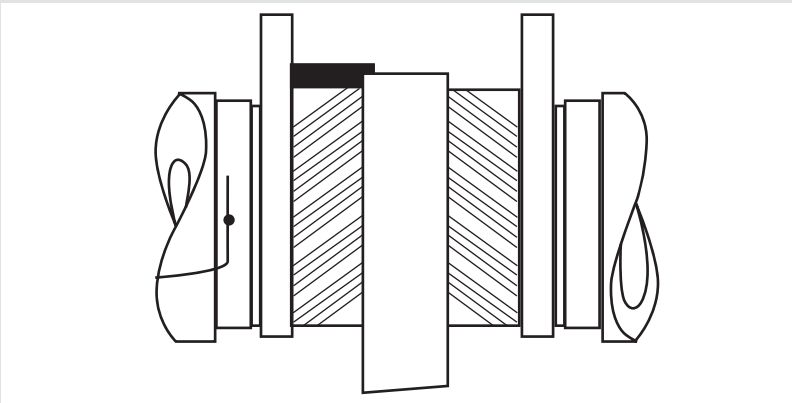

► Damage due to off-centre travel



Brake pads

Use-related damage

Explanation:

- Destruction of the friction material by mechanical and thermal overload in some places.



Explanation:

- Inadequate clearance of the brake pads due to faulty brake.
- Can occur both wheel and axle-wise.

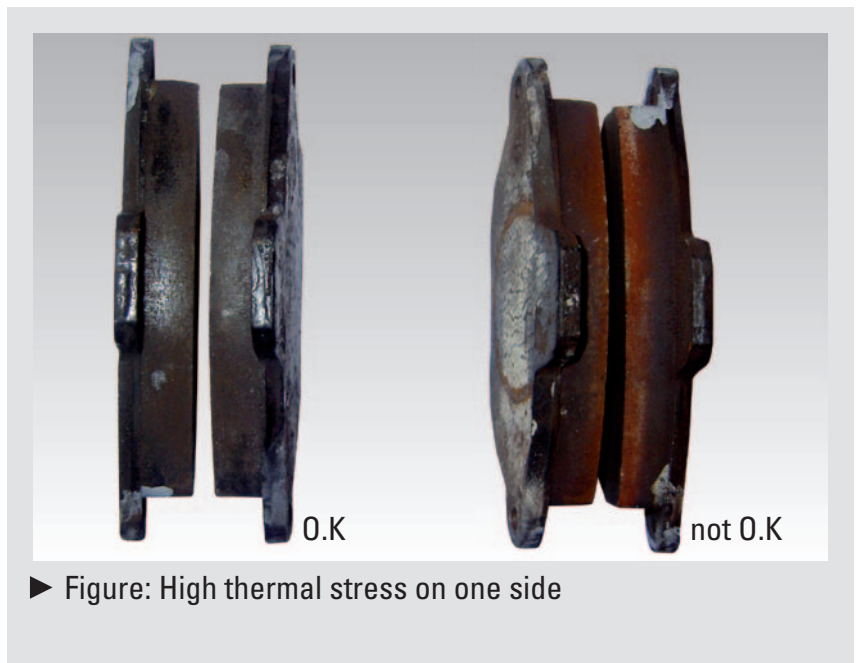



Brake pads

Production faults

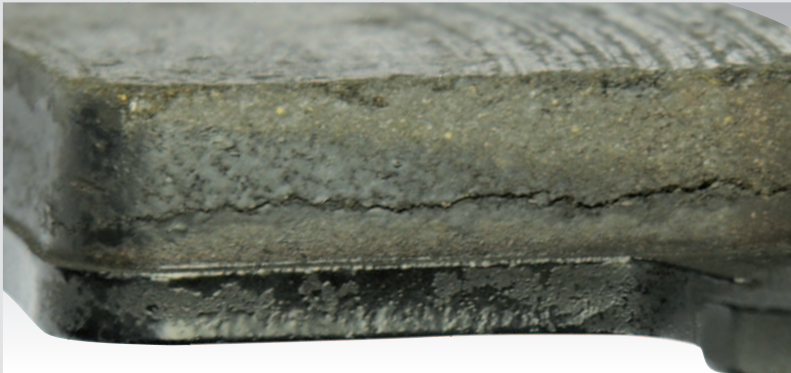

► Delamination / cracks on new brake pad

Explanation:

- Inadmissible pressing fault
- Cracks parallel to backing plate are always inadmissible.

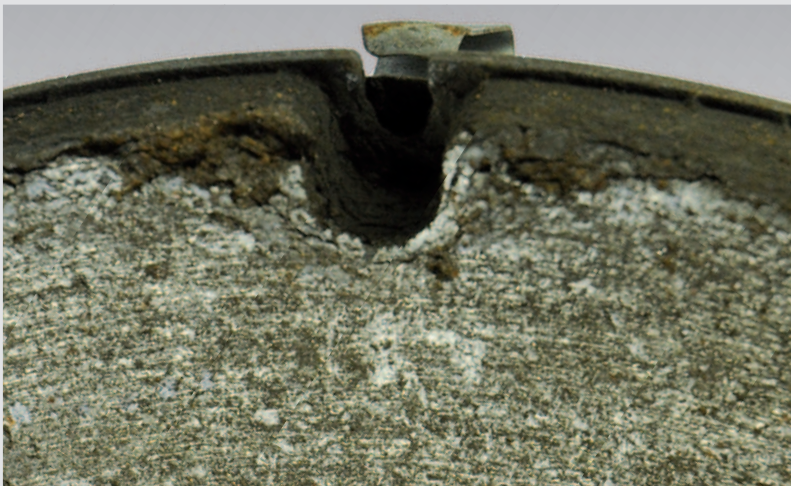

► Break-offs on the surface, no sign of high thermal stress visible

Explanation:

- Inadequate stability of the friction material as a result of pressing fault, leads to porosity and break-offs on the surface.



Brake pads

Production faults

Cause:

Inadmissible pressing fault



Cause:

Design-related pressing overhang to completely utilise the friction ring of the brake disc.



Explanation:

Foreign bodies are always inadmissible, inhomogeneous mix proportions are permissible up to a maximum of 5% of the surface.





Brake pads

Fitting fault



Cause:

Incorrect fitting position

► Visible imprints / traces on the backing plate



Cause:

Improper handling
prior to / during fitting

► Piston spring bent; this is not permissible



Brake pads

Fitting fault

Cause:

Brake pad fitted improperly



► Hold-down spring broken

Cause:

Accessory is subject to use-related wear and, depending on the model type, is included in the scope of supply.



► Clip-on plates worn

Cause:

Positioning device ignored

Attention:

Pay attention to correct seating in the calliper in order to ensure perfect functioning.



► Piston imprint on the positioning device



Brake pads

Fitting fault



► Obvious damage due to external influence

Cause:

Brake duct not freed from contamination and corrosion.
Dimensional deviation of backing plate.



► Cut-out in the damping plate is not functioning due to contamination.

Cause:

Brake housing not freed from contamination and corrosion;
excessive greasing.



► Improperly changed pad geometry

Cause:

Inadmissible alteration
during fitting



Brake pads

Fitting fault

Cause:

Incorrect seating of the brake pad in the calliper.

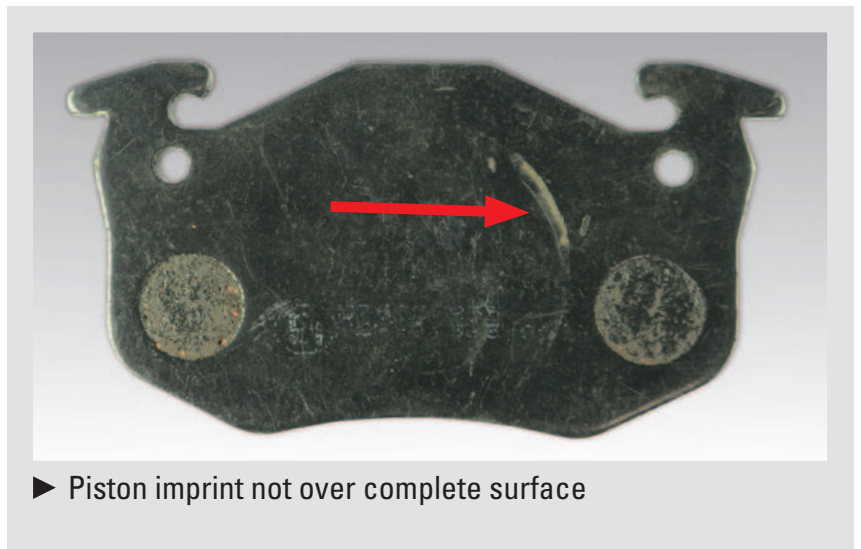

Cause:

Stepped piston misaligned in the calliper housing.

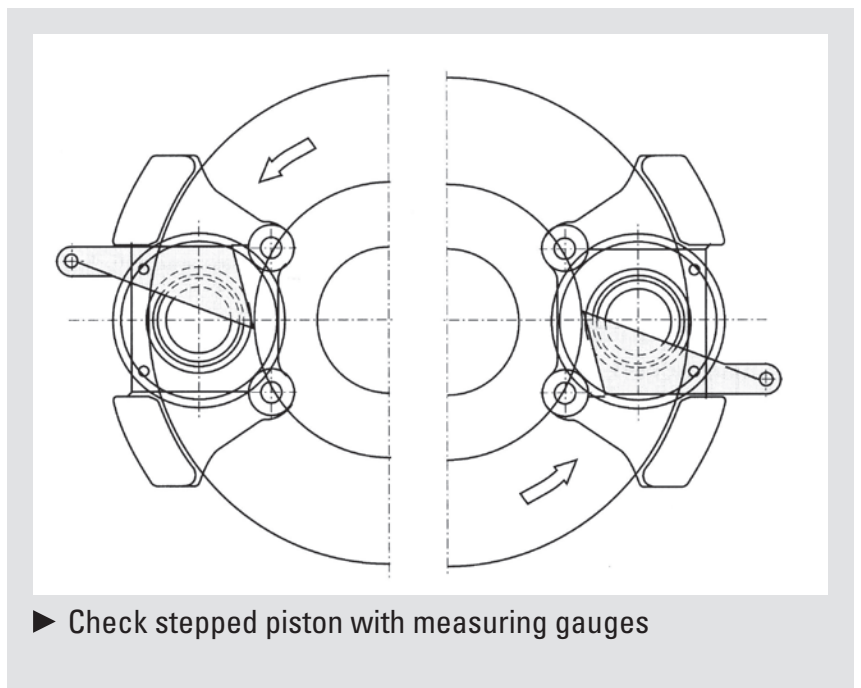



Brake pads

Damage due to environmental influences

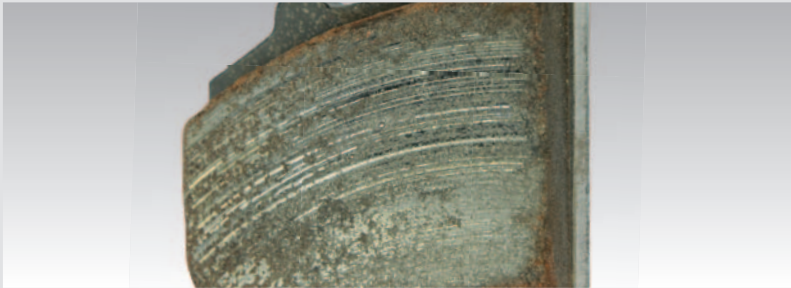

► Vitrification of the friction surface



► Contamination of the friction surface

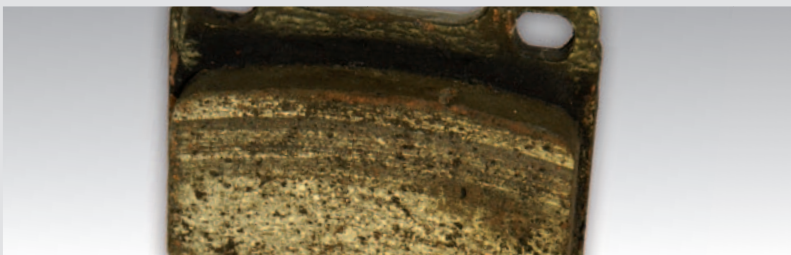

► Deep scoring in the pad surface



► Residues – metal pick-ups in the pad surface

Cause:

Inadequate contact pattern, no cleaning braking after temperature load.

Cause:

The operating temperature is often not reached; self-cleaning does not take place. Contamination of the friction surface by, e.g., corrosion, dirt, paint, or salt.

Cause:

Use of scored brake disc. Ingress of foreign bodies such as dirt, salt or corrosion. Inadequate distribution of friction particles in the friction material.

Cause:

Material transition from the brake disc onto the brake pad due to, e.g., different loading, climate and/or material incompatibility.



Brake pads

Attention:

Special fitting instructions regarding secondary measures must be followed to prevent noises, judder phenomena, disc cracks, as well as uneven wear.

Special fitting instructions



► Special fitting instructions regarding secondary measures.



Brake pads



All damage symptoms listed are exemplary and, depending on the brake / vehicle design, can have different impacts.

They serve as guidelines, but cannot replace the on-the-spot damage assessment of the expert. They often occur in combination.



Brake discs for passenger car brakes

Differentiation between “thermal judder” and “cold judder”

Brake judder

The term “brake judder” refers to non-uniform braking torques – and therefore to brake force fluctuations – which occur during braking or, more precisely, in the course of a full brake disc revolution. These phenomena, which have different causes, are divided into thermal judder, which occurs during deceleration from high speeds, and cold judder, which can occur at any speed.

Thermal judder

“Thermal judder” can be described as follows:

- A **booming judder** in a frequency range between 100 and 250 Hz. The intensity of the booming can vary during deceleration but does not affect braking.
- **Torque fluctuations** can often be felt as a vibration in the steering wheel, pulsation in the brake pedal and vibrating chassis components.

The occurrence of brake judder depends on the pedal force. Thermal judder can usually be identified by a circular arrangement of **spots** on the brake disc’s friction surfaces. These are caused during braking by local overheating, which results either in a transfer of material from the brake pad to the brake disc and/or a permanent change in the structure of the brake disc casting material. Transferred material is usually removed when braking normally, but structural changes – also referred to as martensite formation – which are harder than the disc material’s basic structure and can be removed only by machining. When repairing a disc with martensitic spots, it is important to completely remove the hardened areas. To prevent risks, the disc should ideally be replaced.

Spot formation through local overheating is caused by several factors:

- The disc can under certain conditions distort when heavy braking takes place. This flexing of the disc can result in permanent distortion.
- The brake disc has worn below the minimum thickness (see manufacturer’s recommendation), which reduces the disc’s capacity to dissipate heat.
- The disc brake pads are **excessively worn** and have an **insufficient braking effect**.
- The brake disc casting and tolerances do not conform to the manufacturer’s specification.
- The disc brake pads fitted are unsuitable for the application and/or **do not comply with the original equipment** or any comparable quality standard.
- The brake system is not working correctly or some of its components are not dimensionally correct.

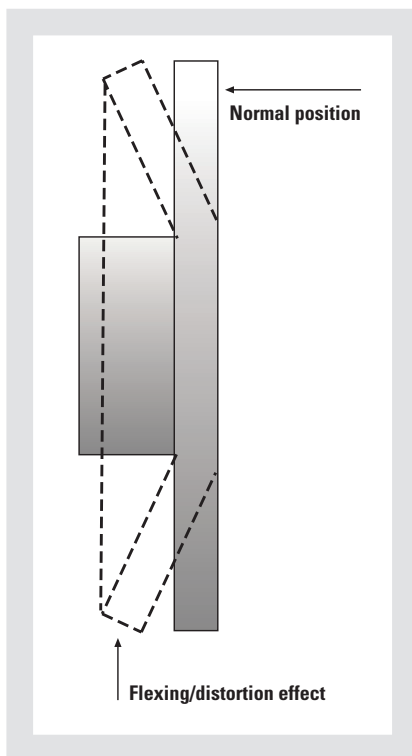



Brake discs for passenger car brakes

In addition to the causes of “thermal judder” due to local overheating described above, other factors which can cause or increase the likelihood of thermal judder include poorly balanced wheels, worn bearing components in wheel suspension system, steering and a misaligned front axle.

In most cases, judder is caused by several factors, making it difficult to clearly identify the root cause.

Thorough and careful investigation of the cause and remedying of the fault is, therefore, necessary. This work should be carried out by a specialist repair shop with a high level of experience.

The investigation essentially consists of the following test procedures:

- First determine whether the judder is coming from the **front or the rear axle**.
- Perform a **visual inspection** to determine which functional components are worn and to what extent. Heavily worn or grooved discs or pads must always be replaced as an axle-set.
- Verify that the brake pads fitted have been approved for the application in accordance with the **manufacturer’s recommendation**.
- Check the **operating condition** of the disc brake, paying special attention to caliper components, and repair, if necessary. Repair should be carried out by a specialist workshop.
- Check whether the **wheel** is out of balance and rebalance if necessary.
- Check the operating condition of the **suspension** and the **steering components** and replace any faulty parts.
- Check the individual components of each **wheel bearing** for defects (bearing clearance) and replace if necessary.
- Check and, if necessary, correct the **axle-geometry** according to the vehicle manufacturer’s guide values.

Thermal judder can usually be reduced by choosing suitable friction materials, provided that the other vehicle components referred to are in a fault-free condition. When an optimisation of this kind is performed, it must be kept in mind that it complies with all the requirements set for the braking system.

Test procedures



Brake discs for passenger car brakes

Cold judder

“Cold judder” occurs during normal braking and can be identified by pulsation in the brake pedal, torque fluctuations in the steering wheel and/or vibration of axle and chassis components.

The **characteristic differentiating** this from “thermal judder”, is that cold judder can occur virtually every time the brake is applied, and has a much lower frequency range (about 5 to 50 Hz). The intensity of the judder may also vary with the vehicle’s speed.

Cold judder is caused mainly by **variations in the thickness of the disc and similar to** thermal judder, can be amplified by faulty bearing components and out-of-balance wheels.

How does this thickness variation come about? Every brake disc contains **radial run-outs** caused by production and assembly tolerances. Disc brake pads will always make some contact with the brake disc during unbraked driving, and this contact will be most pronounced at certain points of the discs. Although the contact forces are relatively low, they cause wear at these points of the brake disc. This results in a disc thickness variation, which eventually causes judder. Providing certain prerequisites are fulfilled, this disc thickness variation can usually be reduced or eliminated again by normal braking, which keeps the alternating generation and reduction of thickness variations acceptably balanced. We will deal with these prerequisites later on.

Causes of non-uniform thickness

The following **factors influence disc thickness variation**:

- **radial run-outs** of the brake discs in the fitted state;
- brake pads rubbing onto the disc in the unbraked state;
- the **ability** of the disc brake pads to reduce or remove disc thickness variations during normal braking;
- correct caliper actuation that allows the release of the brake pads from the brake disc;
- the **road and environmental conditions** and the driver’s driving style.

The effects of existing and identical **variations in disc thickness** can vary significantly from one model to the next and depend on the force transmission factors and the damping capabilities of the axle, steering and chassis components.



Brake discs for passenger car brakes

When investigating the causes of judder, **keep the following points in mind:**

- **Radial run-out** of brake discs **should be tested** with the disc installed on the vehicle, ideally with a correctly fitted wheel. Radial run-out is tested with a dial gauge with a measurement accuracy of at least 0.01 mm and applied about 10 to 15 mm below the outer disc radius. A measurement on the mean friction radius is sufficient, however. The reading on newer vehicles should be taken over several revolutions and the run-out should not exceed 0.070 mm (Problem vehicles: < 0.040mm). Note that this test yields valid results only on new brake discs.

Due to the component tolerances such low readings can not be achieved on older cars. An optimisation can still be achieved, however, by positioning the brake disc on the hub to the fastening bores so that the lowest measured value is achieved. But even on older cars, brake disc radial run-outs must not exceed 0.10 mm. If necessary, the component(s) causing the run-out (hub, brake disc, bearings) must be replaced. Take care that the contact surfaces is kept clean and free from defects.

- As mentioned above, the **hub** can also cause excessive radial run-out and therefore must be measured. In this context, a maximum value of 0.030 mm, referred to the outer measurable radius, can be taken as a guide. If the deviation exceeds this value, the hub should be replaced.
- A further factor affecting radial run-out is brake **disc ripple**. The disc's parallelism should therefore also be checked and should not exceed 0.050 mm. Specialist equipment is necessary for this test.
- For a precise **measurement of disc thickness variation**, specialist equipment is required, although a precision micrometer gauge with a measuring accuracy of 0.001 mm will yield sufficiently precise results. Measurements should be taken at 12 to 15 points around the disc's circumference and about 10 to 15 mm below the disc's outer friction radius. Depending on the vehicle type, thickness variations as low as 0.012 to 0.015 mm (Problem vehicles: < 0.008mm) can cause judder. On new discs these values must not be exceeded. They are also the absolute tolerance limit for Textar brake discs.

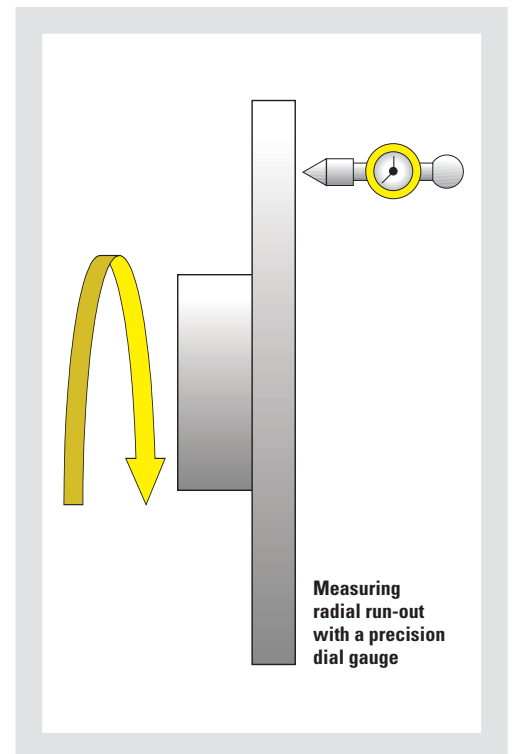



Brake discs for passenger car brakes

Further testing

In addition to these tests, some of the test procedures described in the section about “thermal judder” should also be performed. These include checking the disc brake’s operating state, the wheel bearings, suspension and steering components, the front axle adjustment and the use of car manufacturer-approved disc brake pads.

As we have shown, the causes for excessive radial run-out and disc thickness variations can be difficult to identify. But by performing the possible measurements on the affected components and – if necessary – replacing them, these faults can largely be limited to acceptable levels.

As already mentioned, driving style as well as traffic and road conditions also play a part in causing brake disc thickness variations. Journeys of several thousand kilometres with little braking at low frictional power generation can result in sufficient disc thickness variations to cause judder. A subsequent driving phase containing a lot of braking can regenerate the discs again.

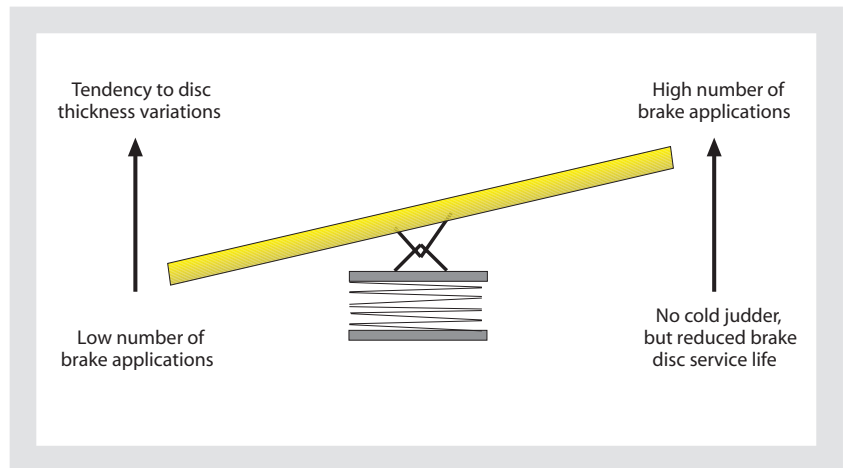



Brake discs for passenger car brakes

Judder caused by static spots

If a vehicle is not driven for a longer period, and especially if it is exposed to moisture and/or salt, corrosion can cause the brake pads to adhere to the disc or the area of the disc opposite the pad **can corrode to such an extent** as to cause severe judder. Corrosion adhesion can often be freed by releasing the clutch quickly in first gear to gently jerk the vehicle forward. If the adhesion is severe, dismantling the brake system and regrinding or replacing the brake discs may be the only remedy. If the brake pads are damaged they will have to be replaced. Slight judder after a longer time of non-use may disappear after the car has been driven for a while. If the judder is severe or does not go away by normal braking, the brake discs must be reground or replaced.

Squeaking noise during braking

Provided that the brake system does not exhibit any design or other fundamental faults, the brake disc contributes to a squeaking noise only if the gap between it and the brake pad is inadequate or the disc surfaces are damaged or corroded. It is true to say, however, that brake discs, because of their geometry, are suspect to noise issues.

This fault can be remedied as follows:

- Check the **state of wear and the surface condition** of the brake pads and brake discs and replace them if necessary.
- Verify that the fitted brake pads are **manufacturer-approved and suitable** for the vehicle.
- Check that **anti-noise elements** (damping shims, damping lacquer, pastes) are fitted and in good working condition.
- Check the **freedom of movement** of the brake pad guide ramps and caliper piston.

Disc brakes achieve their braking effect through dry friction, which inherently tends to cause vibration and therefore noise. Because of the influencing factors and operating conditions described above, a complete suppression of braking noise is extremely difficult, but with modern technology a high level of noise suppression can be achieved.



Brake discs for passenger car brakes

Poor braking effect

Further possible defects

In most cases – especially on front wheel brakes – the problem is not caused by the brake disc.

In these cases check whether suitable brake pads have been fitted and are not excessively worn, that the surfaces of brake discs and pads are free from defects and that the brake system (pistons, guides, servo units) is working correctly.

On **rear axle disc brakes**, insufficient specific load can cause corrosion of the brake disc or surface conditioning of the friction components, which in turn reduces the brakes' effectiveness. However, due to the low rear axle brake force fraction, this is barely noticeable for the driver. In these cases the brake discs must be reworked or replaced, and the brake pads should also be replaced.

Brake discs exhibit cracking

Thermal shock loads on the surface of the brake disc can cause cracks in the cast structure. These cracks reduce the brake disc's strength and can, depending on their size and the applied forces, result in material fracture. At what size cracks begin to represent a problem is difficult to say, but to **prevent failure** with its potentially fatal consequences, brake discs on which cracking is clearly visible without technical aids, should be replaced. It is also worth noting that the likelihood of fracture increases with the length of the cracks.

In addition to presenting a risk of disc fracture, a cracked disc surface acts like a machine tool on the brake pads, causing excessive pad wear, which becomes more pronounced at higher temperatures, at which the crack width increases.



Brake discs for passenger car brakes

Brake discs are scored

Score marks on the friction ring surface can have various causes:

- **unsuitable friction material** of the brake pads;
- **severe soiling** of the brake discs or pads;
- **corrosion**;
- **overloading** of the brake system;
- **unsuitably soft** brake disc material.

Scoring can have a wide range of structures, from very fine to very coarse, which makes it difficult to define clear rules about the extent of scoring that is still acceptable. In general, an experienced mechanic can usually judge whether or not a scored disc needs to be replaced or reworked. Up to a point, scoring does not affect the braking effect, but if the brake pads are replaced, the discs have to also be replaced or reworked.

Brake disc service life is too short

The useful life of brake discs and brake pads is only one – albeit very important – aspect in the development of a brake system. For normal usage conditions, the design life of the front wheel brake discs should be equivalent to the useful life of two sets of corresponding brake pads. Some discs may have a shorter useful life, because they have been designed to achieve specific targets on which more value is placed, for example to prevent unwanted **effects such as cold judder**.

In practice, the useful life of a brake disc depends on the following influencing factors:

- the driving style;
- road and traffic conditions;
- topographic and climatic conditions;
- the level of dirt and contamination;
- the brake disc's casting material and structure;
- the aggressiveness of the brake pads;
- the freedom of movement of the sliding and guide elements and the brake actuating piston.

Because of the many influencing factors, in practice, brake disc life turns out to be a statistical figure; the distribution function shows that some discs last 10 to 15 times longer than others. Some discs reach the end of their useful life after just 20,000 kilometres, others may provide trouble-free service for as much as 300,000 kilometres, while even lower or higher mileages are possible in individual cases. This makes it impossible for manufacturers and distributors to offer any guarantee for the useful life of their brake discs.



Brake discs for passenger car brakes

Typical examples of described disturbance factors

Summary and illustrations

Analysis shows that a **large proportion** of customer **complaints** about faulty brake systems are attributed **to the brake disc**. And in those cases, in turn, brake judder is the main cause for complaint.

Because of the complexity described above and the numerous possible influencing factors, brake disc damage and its causes are often difficult to identify in any particular case. Experience has shown that, in most cases of actual brake disc damage, the root cause usually lies elsewhere (excessive disc run-out due to overall tolerances, unsuitable brake pads, faulty wheel brakes, etc.). In many cases, the brake discs about which a complaint has been received, prove to be in perfect working condition and the root causes of deficiencies have not been identified. This inevitably leads to complaints being rejected after costly and time-consuming tests, much to the annoyance of all parties concerned. Even if the immediate problem seems to be solved by a replacement of certain parts, the symptoms usually reappear after a while.

This situation can be improved – and customer satisfaction guaranteed – **only if the root causes can be reliably determined and only if approved spare parts are used and maintenance jobs are carried out with care and precision.**



Brake discs for passenger car brakes

Thermal judder

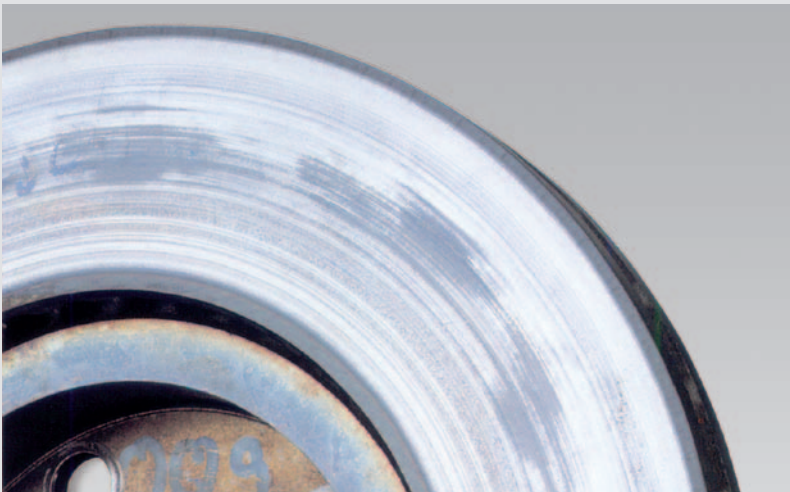

► “Judder marks” through local overheating of brake disc

Booming judder and vibration during braking from high speeds

Cold judder

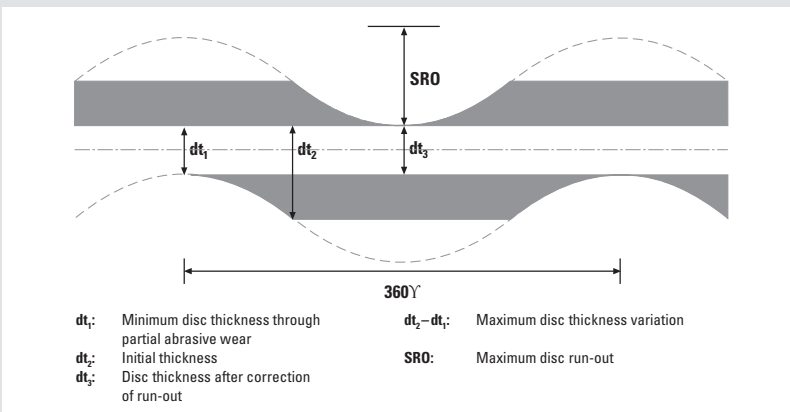

► Disc thickness variation of brake disc

Identification:
Vibration of chassis parts and friction-induced rotary vibrations or pulsation of the brake pedal during braking at almost any speed



► Measuring disc run-out on the vehicle



Brake discs for passenger car brakes

Cause:

Corrosion, caused by humidity, salt or other environmental factors.

Static spots



► Brake disc with static spots

Cause:

High alternating thermal and mechanical loads.

Cracked brake discs

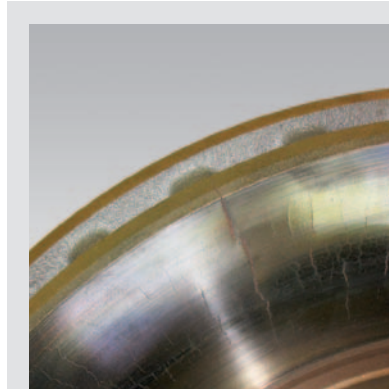

► Brake disc with severe heat cracking

Cause:

Brake disc worn beyond permissible wear limit.

Identification:

Suddenly occurring, severe signs of judder



► Cracked brake disc



Brake discs for passenger car brakes

Scored brake disc



► Brake disc with score marks

Cause:

Soiling, overload, unsuitable disc and/or brake pad material.

Completely worn brake pads



► Friction material worn down to the steel back plate

Cause:

Brake pads not replaced in time.



► Brake discs damaged by worn friction material



Brake discs for passenger car brakes

Cause:

Long time out of use in damp conditions, structural changes in the friction ring as a result of widespread static spot formation.

Symptoms:

Rough brake, braking noise, signs of judder.

Corroded brake discs



► Corroded brake disc

Inner and outer friction rings have different thicknesses

Design-related for different heat absorption.

Max. permissible difference per friction ring is 0.5 mm.

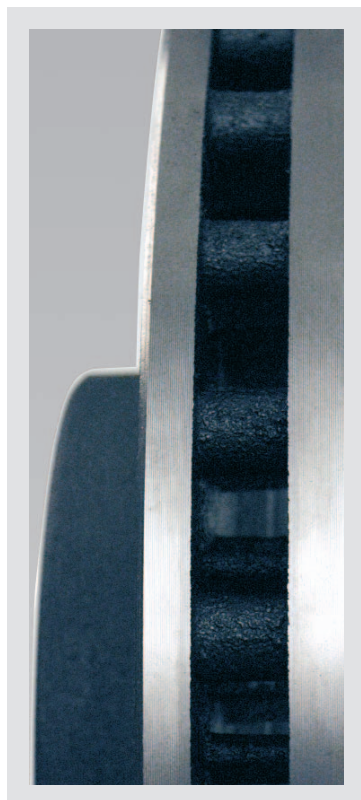



Brake discs for passenger car brakes

Thickness variation in friction ring



▶ Disc thickness variation

Cause:

Incorrect processing, operation with excessive disc run-out combined with simultaneous insufficient brake loading.

Symptoms:

Cold judder

Heavy underlying corrosion at the contact surface



Cause:

Insufficient cleaning, insufficient contact due to contamination.

Symptoms:

Causes disc thickness variations as a result of impermissible radial run-out.



▶ Heavy underlying corrosion



Brake discs for passenger car brakes

Cause:

Fault during the casting process.

Effect:

Reduction of stability

Blowhole damage

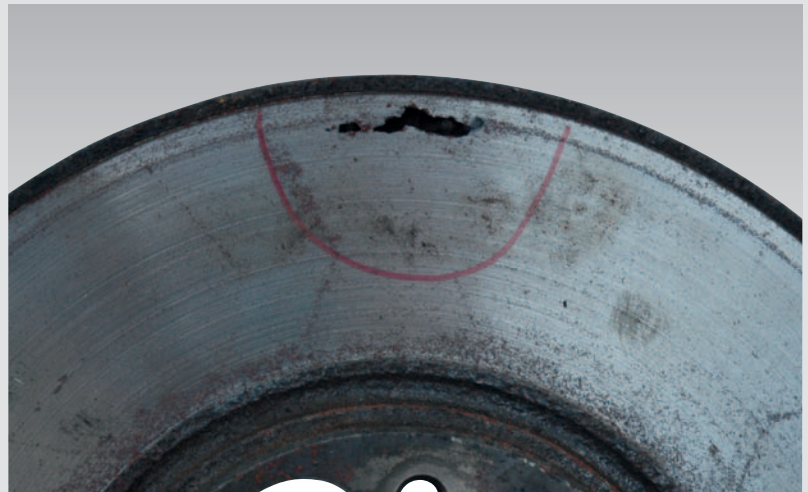

► Blowhole damage

Cause:

- Mounting fault (incorrect torque when mounting the brake disc).
- Incorrect seating of the brake disc as a result of non-adherence to the manufacturing tolerances.

Effect:

Reduction of stability; brake noise

Cracks in the area of the brake disc chamber

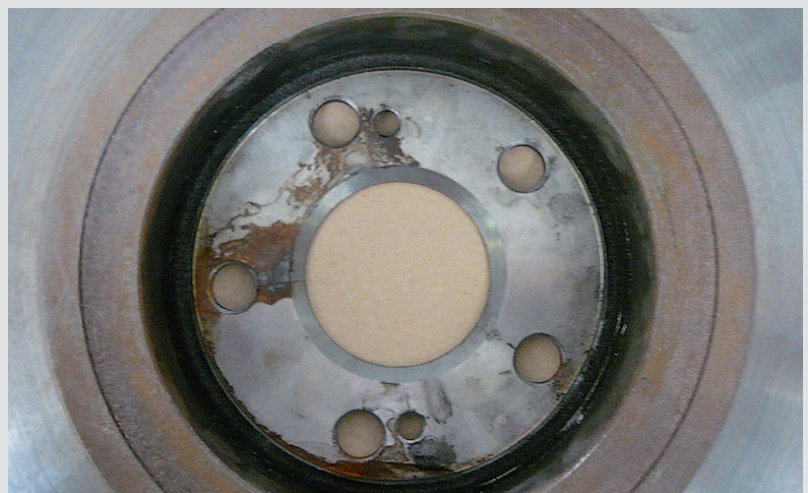

► Cracks in the area of the brake disc chamber



Fault assessment of disc brake pads and brake discs

Further information is available on the Internet:

The screenshot shows the Textar website homepage. At the top, there is a yellow header with the Textar logo and navigation links for 'HOME', 'CONTACT', and 'SUPPORT'. Below the header, there is a main navigation menu with categories like 'PRODUCTS', 'MARKETING', 'SERVICE', 'DOWNLOADS', and 'TMD FRICTION'. The main content area features a 'PRODUCT OVERVIEW' section with a list of products such as 'Textar Passenger Car Ramps', 'Textar Commercial Vehicle Ramps', 'Textar Axle', 'Textar Brake Shoes', 'Textar Brake Discs', 'Textar OE Line Brake Discs', 'Textar Brake Pads', 'Textar Brake Cleaner', and 'Textar Spare Parts'. There is also a 'BRAKESBOOK' and 'NEW TO RANGE ITEMS' section. A 'News & information' section includes links to 'Brakebook Online Catalogue', 'Textar OE Line Original equipment brake discs from Textar', and 'Textar @ Facebook'. A 'Textar - O.E. approved - aftermarket leading' section highlights the company's history and quality standards. At the bottom, there is a 'TMD' logo and copyright information.

www.textar.com



Textar Service Line

**Telephone number:
+49 (0)2 171 / 703 397**

Call us with your questions about products and technical issues. We would also be pleased to hear your advice and practical experience. The line is open during business hours.



Fault assessment of disc brake pads and brake discs

Notes



Fault assessment of disc brake pads and brake discs

Notes
